

CAD FILE:

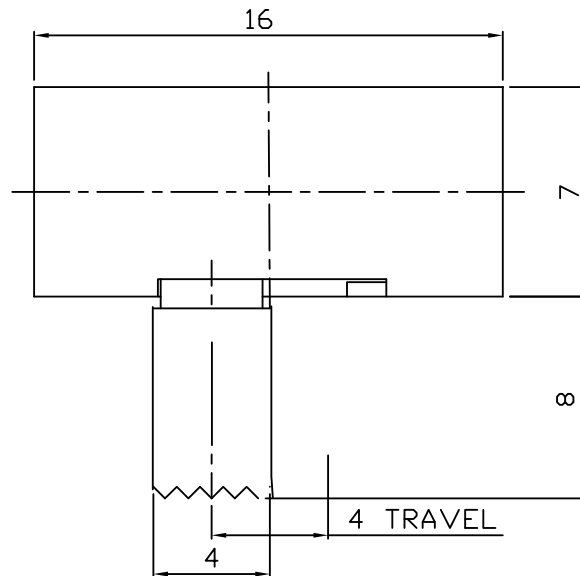

MODEL NO.	KNOB(G/VG)
SK33H03-8	8 mm

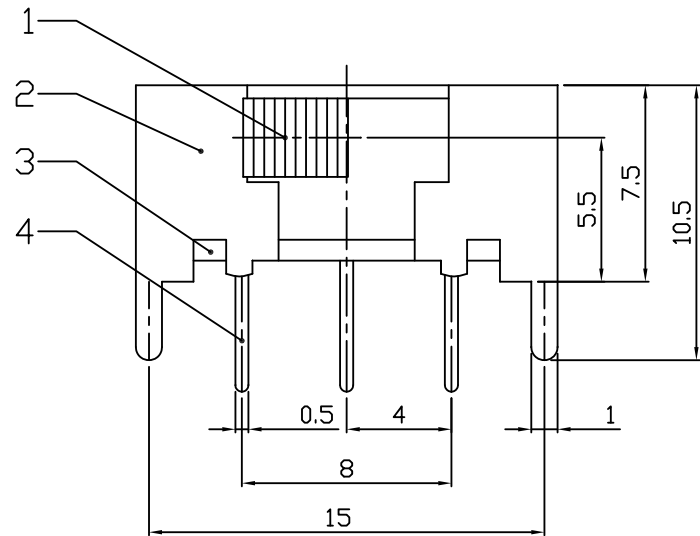
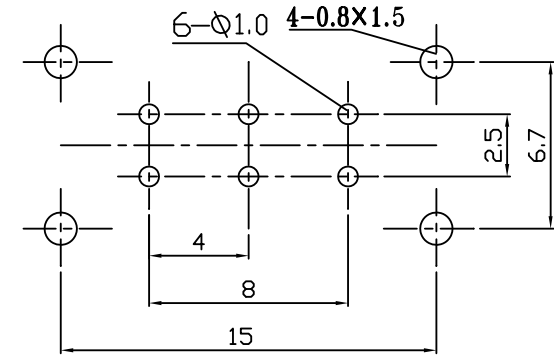

P.C.B. LAYOUT

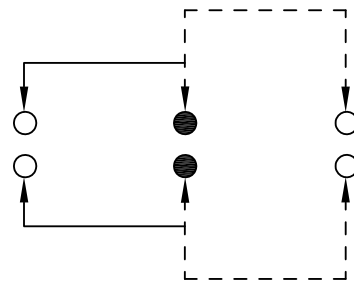
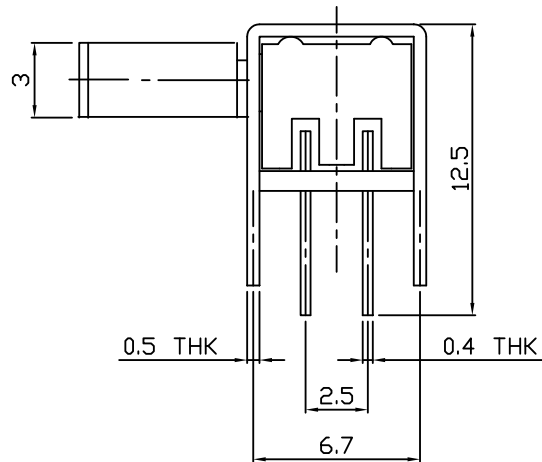

SCHEMATIC (NON-SHORTING)

SPECIFICATIONS	
Rating	0.3A 50V DC
CIRCUIT	2P2T
Timing	NON-SHORTING
Travel	4.0mm
Contact Resistance	< 100 mΩ
Operating Force	250gf ± 100gf
Operating Life	10,000 cycles

NO.	PARTS	MATERIALS	Q'TY	FINISH
8				
7	STEEL BALL	STEEL	1	NATURAL
6	SPRING	STEEL WIRE	1	NATURAL
5	CONTACT CLIP	PBS STRIP	2	Ag PLATED
4	TERMINAL	BRASS STRIP	6	Ag PLATED
3	BASE	PHENOLIC RESIN	1	NATURAL
2	FRAME	STEEL STRIP	1	NI PLATED
1	KNOB	POM	1	BLACK

TOLERANCE UNLESS SPECIFIED WITHIN 1.5mm : ±0.1mm OVER 1.5mm : ±0.2mm		DESCRIPTIONS OF REVISION		APPD.	
		TITLE : HORIZONTAL SLIDE SWITCH		UNIT : mm	DRWG NO.: T3-224003-00
MODEL: SK33H03-8		SCALE: 3:1	DWN.	ERIC	2013-6-17
WinTai-Tech 穩泰電子科技有限公司 Wintai Electronic Technology Co., Limited		CHK'D	MAIKO	2013-6-17	
		APPD.	Coco	2013-6-17	